

3-FAS FULLTRANSFORMATOR

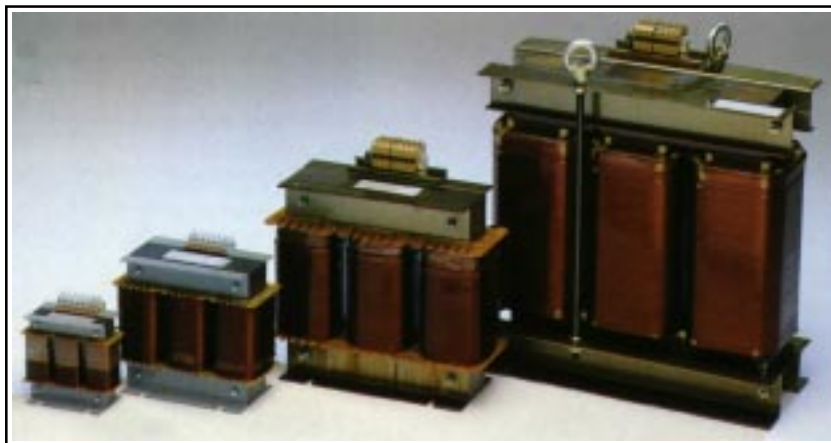

Typserie

TOFS

Stående montage

Ingående komponenter är UL-godkända
 Temperaturklass B/F
 Anslutning: Kopplingsplintar alt. kabelskor
 Koppling: Dyn-11 eller enligt önskemål

ta: 40°C (max omgivningstemperatur)
 ed: 100% (kontinuerlig belastning)
 Sekundär märkspänning beräknas vid 80% belastning

Tillverkningsnormer: EN 61558-2-6 alt. EN 61558-2-1 alt. IEC 726 , EN 50081-2, EN 50082-2



4.10 0205

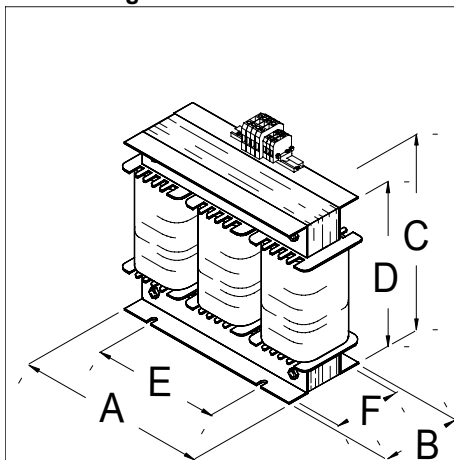

Storlek 0,01 kVA - 15 kVA

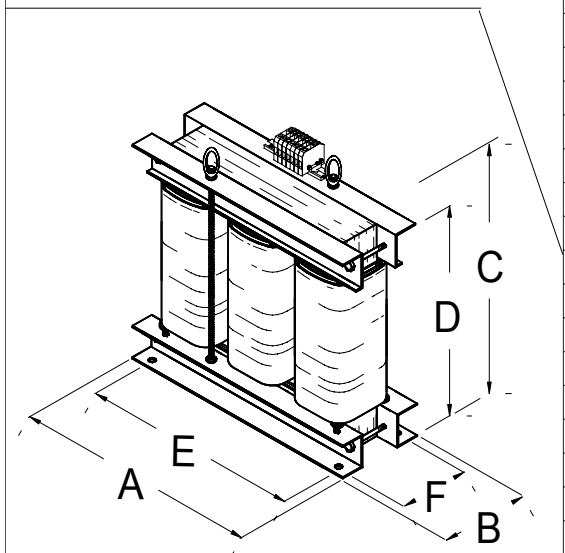

Storlek 20 kVA - 150 kVA

Typ	Effekt kVA	A	B	C	D	E	F	Slits/hål	Vikt kg(ca)	Förluster ca Po(W)	Pcu(W)	uk%
TOFS- 0,01..0,06		120	75	125	102	67	48	7	1,8	3,5	6	
TOFS- 0,1		120	85	125	102	67	58	7	2,6	5,5	10	8,2
TOFS- 0,2		150	85	150	127	80	56	7	3,7	7	20	9,3
TOFS- 0,3		150	100	150	127	80	71	7	5,3	11	23	7
TOFS- 0,45		177	95	175	152	90	65	7	6,3	12	35	7,5
TOFS- 0,6		177	105	175	152	90	75	7	8	15	42	6,6
TOFS- 0,8		208	105	200	177	110	71	7	10,5	19	50	6
TOFS- 1		208	123	200	177	110	89	7	13,5	27	51	4,8
TOFS- 1,25		240	113	225	202	130	80	7	15	27	67	5,2
TOFS- 1,5		240	123	225	202	130	90	7	18	33	67	4,3
TOFS- 1,75		240	133	225	202	130	100	7	21	38	74	4
TOFS- 2		300	115	310	255	160	76	9	23	37	100	4,8
TOFS- 2,8		300	130	310	255	160	92	9	30	52	105	3,7
TOFS- 3,5		300	145	310	255	160	105	9	38	64	110	3,1
TOFS- 4		300	155	310	255	160	117	9	43	74	110	2,8
TOFS- 5		360	160	355	305	200	115	9	52	86	126	2,6
TOFS- 6,5		360	180	355	305	200	130	9	62	103	150	2,5
TOFS- 7,5 / 8,5		420	175	420	355	240	120	11	70/74	120	180	2,4
TOFS- 10		420	185	420	355	240	130	11	88	130	190	2,3
TOFS- 12		420	200	420	355	240	145	11	100	185	215	1,9
TOFS- 15		420	250	420	355	240	190	11	131	225	310	2
TOFS- 20		495	240	535	465	380	170	11	150	190	780	4,2
TOFS- 25		495	250	535	465	380	180	11	165	220	820	3,7
TOFS- 30		540	250	615	535	420	170	12	200	275	830	3,3
TOFS- 40		540	280	615	535	420	200	12	250	360	920	2,8
TOFS- 50		670	270	655	555	470	180	12	245	210	1040	2,8
TOFS- 60		670	290	655	555	470	200	12	275	250	1070	2,4
TOFS- 70		670	300	805	705	470	200	12	325	280	1330	2,5
TOFS- 80		710	300	805	705	470	200	12	370	270	1430	3
TOFS- 100		710	320	805	705	470	215	12	430	325	1570	2,8
TOFS- 125		710	330	955	855	470	220	12	530	360	1750	2,5
TOFS- 150		810	340	955	855	470	230	12	610	420	2200	2,6