

# TRAMO

## SWR-M-690 Sine Wave Filter for frequency controlled motors

- Protects the motor against voltage peaks
- Reduces the risk of insulation failure
- Reduces the risk of electromagnetic interference
- Reduces bearing currents in the motor
- Reduces magnetic noise caused by PWM signals
- Reduces semiconductor losses in applications with long motorlines

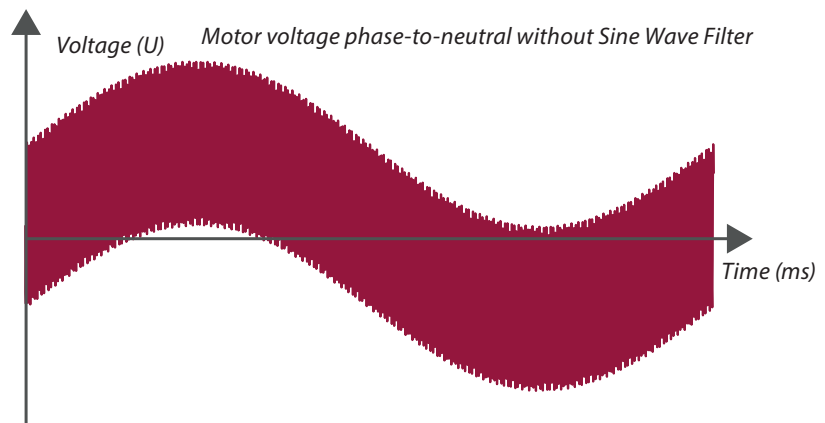
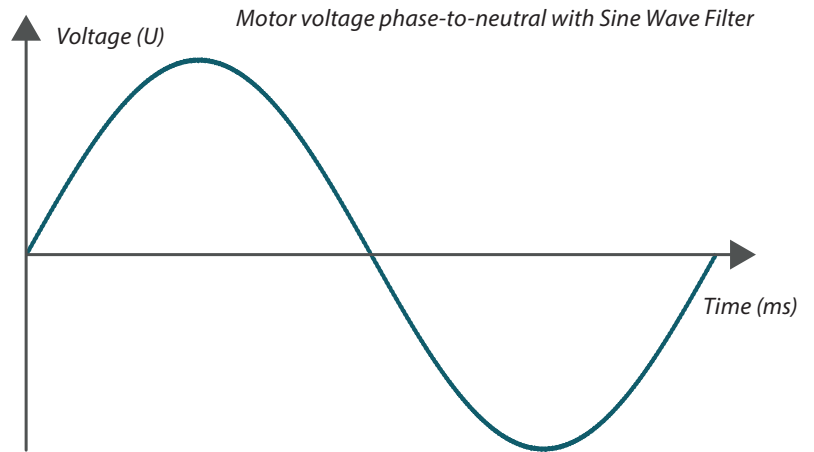

fig 1. Motor Voltage with and without Sine Wave Filter

### BACKGROUND

Frequency-controlled motors face issues such as bearing currents and voltage peaks, which result in significant maintenance costs for millions of motors worldwide. The cause of the problem is built into the principle of converter operation where asynchronous engines are supplied with a frequency modulated voltage wave with a switching frequency of in the kHz range.

This voltage creates a high frequency magnetic field around the motor shaft, which causes inductive or capacitive bearing currents. SWR-M filters out high frequency components from the input voltage, which reduces the amplitude of the common-mode voltage responsible for creating the high frequency magnetic field around the motor shaft. Using a sine wave filter extends the motor's lifespan and prolong the service intervals.

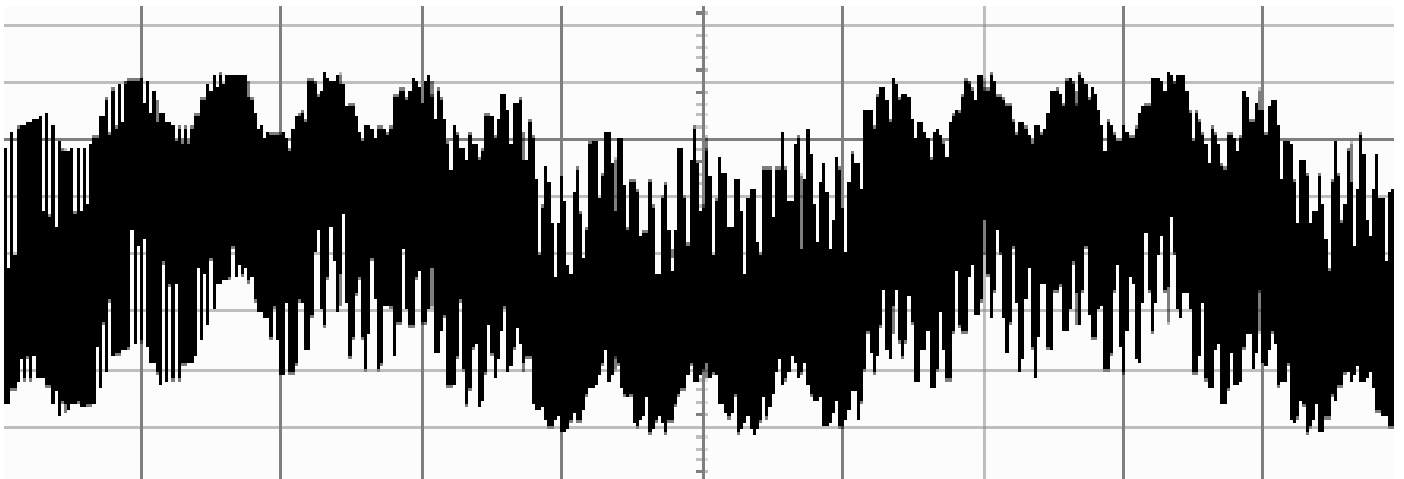

fig 2. Motor Voltage Curve

# TRAMO

## SINE WAVE FILTER (SWR-M)

SWR-M filters out high frequency components in the supply voltage. This reduces the amplitude of common mode voltage that give rise to high frequency magnetic fields around the motor shaft.

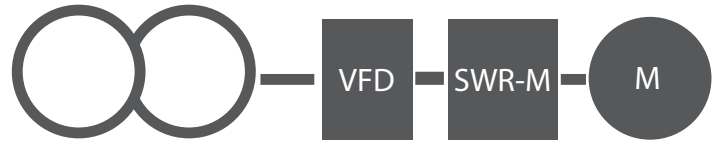

fig 3. Filter configuration

## APPLICATIONS

The sine wave filter can be applied to a variety of applications and requires no modifications to the motor's design. We recommend following applications:

- Motors where magnetic noise caused by pulse-width modulated voltage needs to be eliminated
- Motors used in aggressive environments or at high temperatures
- Applications with motor cables between 150-300m and longer, both shielded & unshielded cables
- Applications where the service interval needs to be extended
- General purpose motors with 690v
- Applications where the frequency converter is connected to a transformer

## OUR OFFER

Tramo provides assistance in all stages of a power quality project. From data collection and power quality measurements to system simulations, recommendations

for corrective actions, filter and filter component design, preparation of technical specifications, and trough to commissioning and verification testing.

## SWR-M, Sine Wave Filter

Electrical engineering table for our seven sine wave filters in the standard range.

Duty cycle	100%
IP rating	IP00
Ambient temperature	-10 to + 40 ° C
Class	B (130) ° C
Standard	IEC 61558-2-20
Cooling	AN

### TECHNICAL DATA

Article number	Name Product name	Nominal Current kW	Nominal Voltage V	Rated Power A	Frequency Hz	PF	Switching Frequency kHz
1000998	SWR-M-690/10	10	690	10	50	0,85	3-6
1000999	SWR-M-690/18	19	690	18	50	0,85	3-6
1001000	SWR-M-690/34	33	690	34	50	0,85	3-6
1001001	SWR-M-690/50	50	690	50	50	0,85	3-6
1001002	SWR-M-690/80	75	690	80	50	0,85	3-6
1001003	SWR-M-690/110	105	690	110	50	0,85	3-6
1001004	SWR-M-690/150	145	690	150	50	0,85	3-6

## SWR-M, Sine Wave Filter

Drawing and mechanical table for following Sine Wave Filters:

- SWR-M-690/10
- SWR-M-690/18

Duty cycle	100%
IP rating	IP00
Ambient temperature	-10 to + 40 ° C
Class	B (130) ° C
Standard	IEC 61558-2-20
Cooling	AN

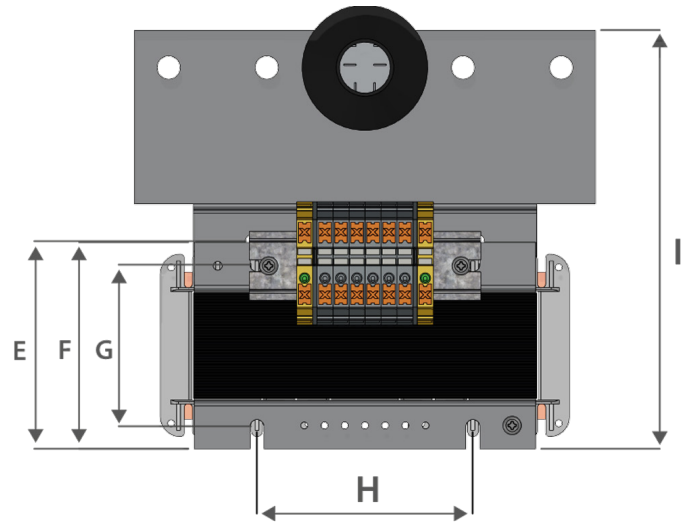
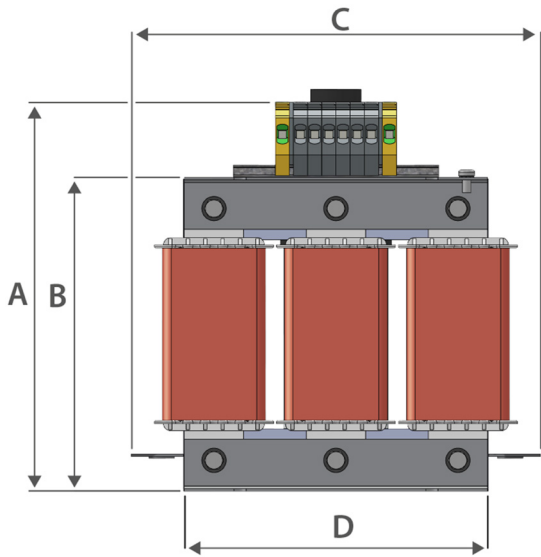

N.B. The C dimension varies for SWR-M-400/10 compared to other sine wave filter.

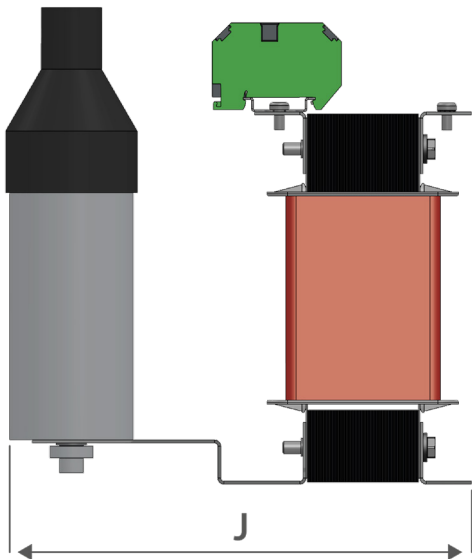

Article number	Name Product name	A mm	B mm	C mm	D mm	E mm	F mm	G mm	H mm	I mm	J mm	Weight kg	Plinth area mm <sup>2</sup>
1000998	SWR-M-690/10	224	181	235	175	106	105	82	110	213	225	15	10
1000999	SWR-M-690/18	251	208	240	200	117	115	92	130	218	233	23	10

N.B. Dimensions and weights are preliminary and will be confirmed upon order

## SWR-M, Sine Wave Filter

Drawing and mechanical table for following Sine Wave Filters:

- SWR-M-690/34
- SWR-M-690/50
- SWR-M-690/80
- SWR-M-690/110

Duty cycle	100%
IP rating	IP00
Ambient temperature	-10 to + 40 ° C
Class	B (130) ° C
Standard	IEC 61558-2-20
Cooling	AN

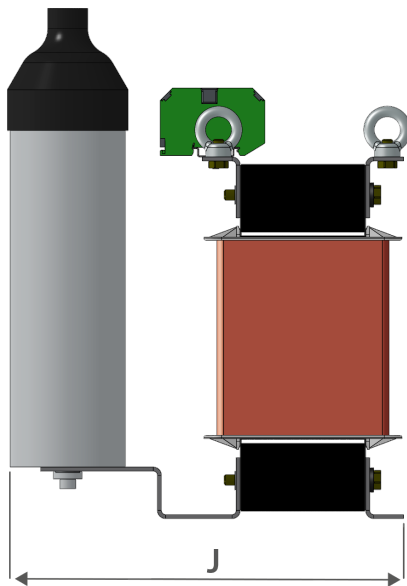
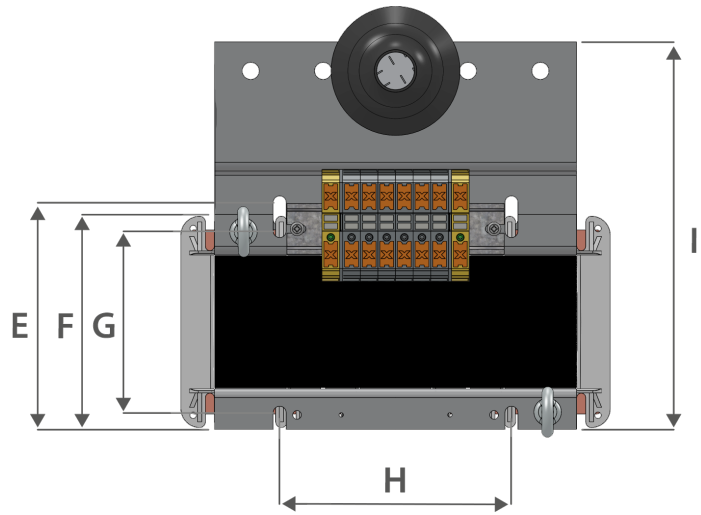
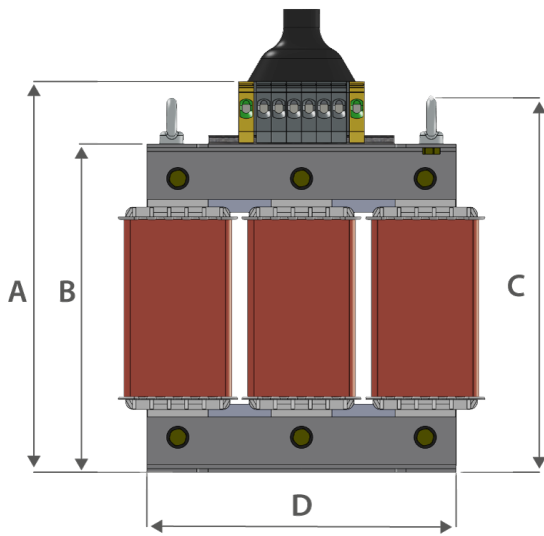

Article number	Name Product name	A mm	B mm	C mm	D mm	E mm	F mm	G mm	H mm	I mm	J mm	Weight kg	Plinth area mm <sup>2</sup>
1001000	SWR-M-690/34	317	266	250	250	117	109	86	160	228	238	33	25
1001001	SWR-M-690/50	317	267	304	250	157	148	125	160	267	290	52	25
1001002	SWR-M-690/80	442	366	416	350	156	143	114	240	275	279	72	70
1001003	SWR-M-690/110	446	366	416	350	181	168	139	240	300	304	95	95

N.B. Dimensions and weights are preliminary and will be confirmed upon order

# TRAMO

## SWR-M, Sine Wave Filter

Drawing and mechanical table for SWR-M-690/150

Duty cycle	100%
IP rating	IP00
Ambient temperature	-10 to + 40 ° C
Class	B (130) ° C
Standard	IEC 61558-2-20
Cooling	AN

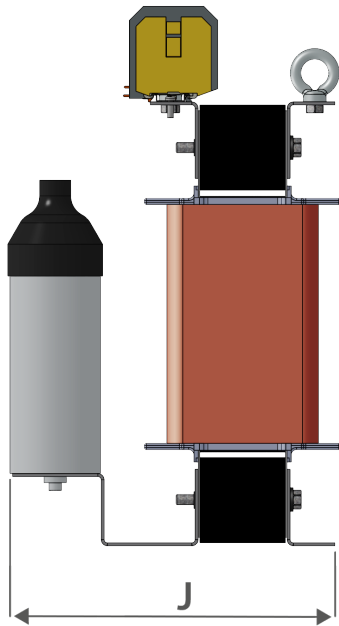
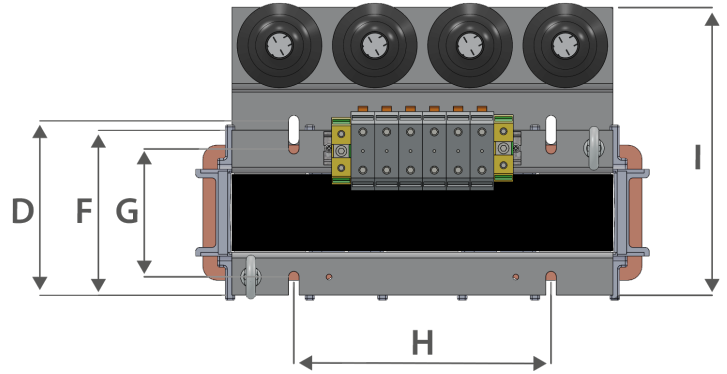
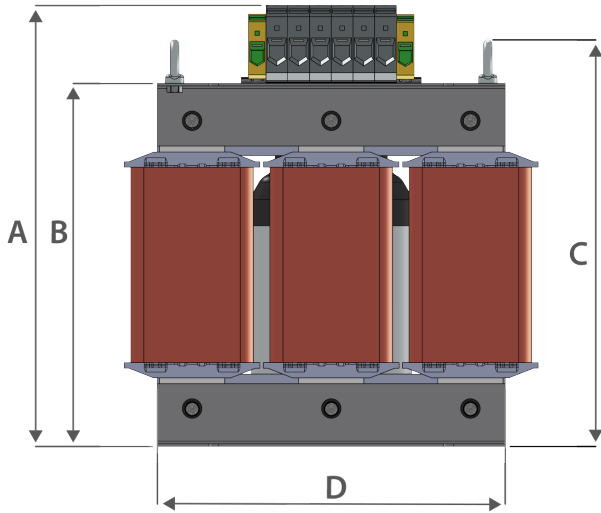

Article number	Name Product name	A mm	B mm	C mm	D mm	E mm	F mm	G mm	H mm	I mm	J mm	Weight kg	Plinth area mm <sup>2</sup>
1001004	SWR-M-690/150	506	417	467	400	183	173	134	270	302	305	118	95

N.B. Dimensions and weights are preliminary and will be confirmed upon order